

TABLE "A" RAFTER SPANS (DOUGLAS FIR #2 OR BETTER)			TABLE "B" HEADER SIZE & SPANS (DOUGLAS FIR #2 OR BETTER)			TABLE "C" FOOTING SIZE BASED ON 1000 P.S.F. SOIL BEARING PRESSURE.		TABLE "D" LEDGER BOLTING Δ
SIZE	SPACING	SPAN	RAFTER SPAN	HEADER				ALL LAG BOLTS SHALL HAVE 1/4" PRE-DRILLED HOLES - (SEE NOTE 2)
				SPAN	SIZE			
2 x 4	12" O.C.	9' - 10"	UP TO 12'-0"	8'-0" MAX	4 x 6	18" SQ. X 12" DEEP		1/2" DIA. X 5" LONG AT 16" O.C. STAGGERED
	16" O.C.	8' - 11"		10'-0" MAX	4 x 8	18" SQ. X 12" DEEP		
	24" O.C.	7' - 8"		12'-0" MAX	4 x 10	18" SQ. X 12" DEEP		
	32" O.C.	*6' - 3"		14'-0" MAX	4 x 12	18" SQ. X 12" DEEP		
2 x 6	12" O.C.	15' - 4"	12'-1" TO 20'-0"	8'-0" MAX	4 x 8	24" SQ. X 12" DEEP		(2) 3/8" DIA X 5" LONG AT 16" O.C.
	16" O.C.	13' - 9"		10'-0" MAX	4 x 10	24" SQ. X 12" DEEP		
	24" O.C.	11' - 3"		12'-0" MAX	4 x 12	24" SQ. X 12" DEEP		
	32" O.C.	*9' - 7"		14'-0" MAX	4 x 14	24" SQ. X 12" DEEP		
2 x 8	12" O.C.	20' - 0"	NOTES: 1. TWO 2X MEMBERS MAY BE SUBSTITUTED FOR ONE 4X HORIZONTAL FRAMING MEMBER. 2. LAG BOLTS MUST FULLY ENGAGE A WOOD STUD OR RIM JOIST AND BE PROVIDED WITH APPROPRIATE WASHERS. LAG BOLTS SHALL BE LOCATED A MINIMUM OF 1-1/2" FROM THE TOP OR BOTTOM OF THE LEDGER. 3. NOT DESIGNED TO BE ENCLOSED - ADDITIONAL ENGINEERING ANALYSIS WILL BE REQUIRED IF ENCLOSED. 4. SEE PAGE 2 OF 2 FOR CONSTRUCTION DETAILS. 5. ARTIFICIAL LIGHTING IS REQUIRED IN ROOMS THAT HAVE WINDOW OPENINGS INTO THE COVERED PATIO AREA IF THE TOTAL WINDOW AREA IN THAT ROOM IS LESS THAN 10% OR THE FLOOR AREA OF THE ROOM OR 20 SQUARE FEET, WHICHEVER IS GREATER.					
	16" O.C.	18' - 2"						
	24" O.C.	14' - 10"						
	32" O.C.	*12' - 8"						
2 x 10	12" O.C.	20' - 0"						
	16" O.C.	20' - 0"						
	24" O.C.	18' - 11"						
	32" O.C.	*16' - 2"						
4 x 4	24" O.C.	10' - 0"						
	32" O.C.	*9' - 3"						
	48" O.C.	*7' - 8"						
4 x 6	24" O.C.	15' - 11"						
	32" O.C.	*13' - 9"						
	48" O.C.	*11' - 3"						
4 x 8	24" O.C.	20' - 0"						
	32" O.C.	*18' - 2"						
	48" O.C.	*14' - 10"						

* THIS SPACING AND SPAN IS FOR LATTICE PATIO COVERINGS ONLY.

Western Riverside County Code Uniformity Program

	COUNTY OF RIVERSIDE BUILDING DEPARTMENT		
	PATIO COVER STANDARD		
(951) 955-1800	4080 Lemon St. 2 nd FL "P.O. Box 1629" Riverside, CV 92501		
(951) 955-1806	1/1/2008 Δ	PatioStd2008.vsd	PAGE 1 OF 2

KNEE BRACE DETAIL AT END POSTS

(REQUIRED WHEN RAFTER SPAN EXCEEDS 12 FT.)

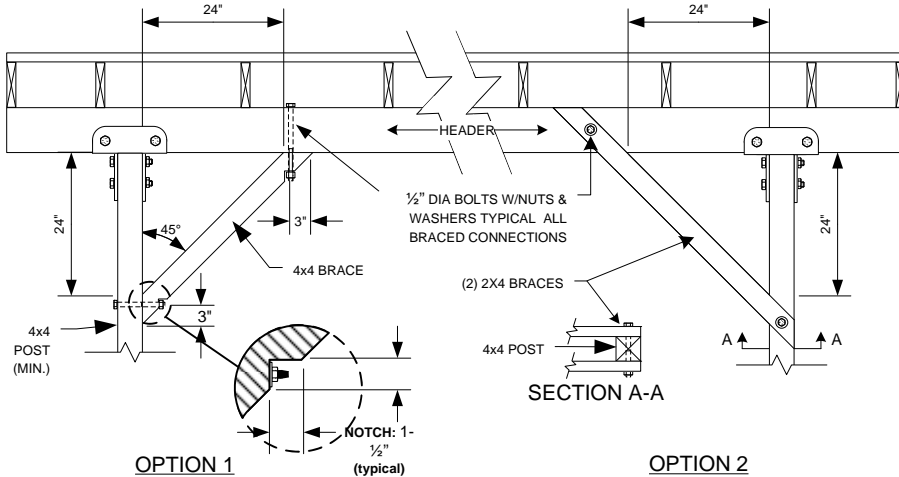

LEDGER ATTACHMENT DETAIL

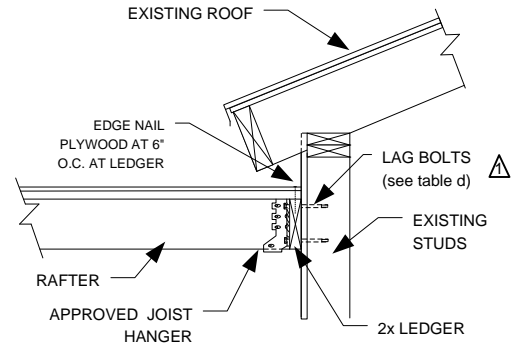

NOTES:

1. USE A CONTINUOUS 2X LEDGER – SAME DEPTH AS RAFTER OR LARGER
2. SEE TABLE "D" FOR BOLTING REQUIREMENTS

INVERTED HEADER DESIGN OPTION (lattice only)

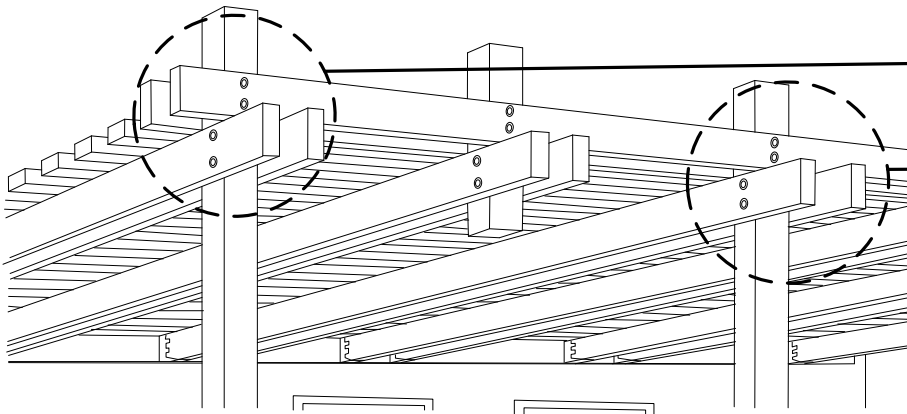

NOTE: KNEE BRACING REQUIRED WHEN RAFTER SPAN EXCEEDS 12 FEET

2X FASCIA (OVERHANG) ATTACHMENT – LATTICE ONLY

OPTION 1

OPTION 2

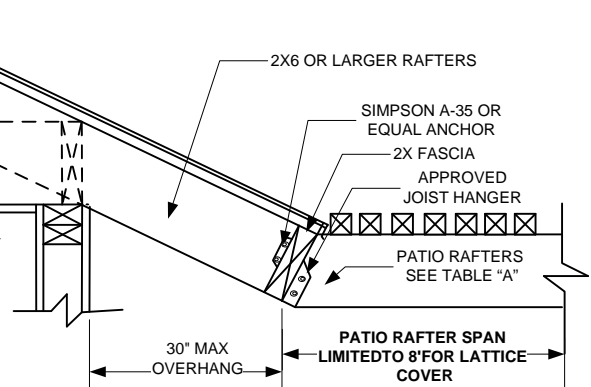
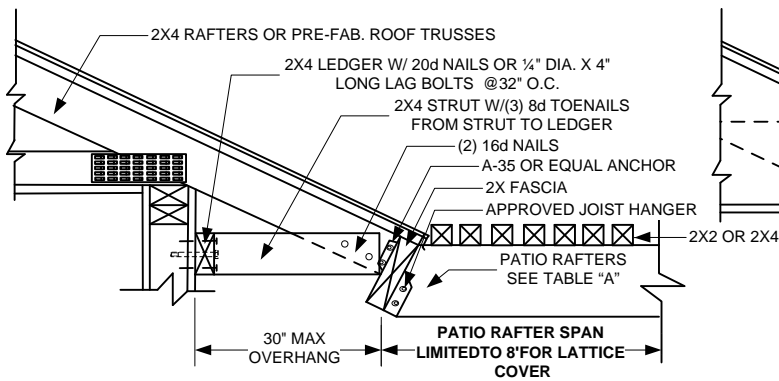

NOTE: VERIFY STRUCTURAL SOUNDNESS OF ROOF RAFTERS FOR DECAY OR TERMITE DAMAGE, AND REPLACE WITH LIKE MATERIALS AS NEEDED, AFTER CONSULTATION WITH THE BUILDING DEPARTMENT.

Western Riverside County Code Uniformity Program



COUNTY OF RIVERSIDE BUILDING DEPARTMENT PATIO COVER STANDARD

4080 Lemon st. 2nd FL "P.O. Box 1629"
Riverside, CA 92501

(951) 955-1800

(951) 955-1806

1/1/2008



PatioStd2008.vsd

PAGE 2 OF 2