

Section 11. General Design Objectives

It is the intent of these guidelines to provide the broadest possible opportunities in site planning, architecture, landscaping and signage, but insure a quality design image for the site, and maintain a competitive development program. In short, the overall objective is to create a project that offers a diversity of compatible land uses but with some reasonable regimentation of design. Most development standards are deferred to the County ordinance requirements, however, project specific design criteria are defined herein to supplement those development standards. Additional criteria will be included in the project covenants, conditions, and restrictions.

Site Planning:

- To encourage a planned image of a quality business park in a clean contemporary environment.
- To locate buildings in a manner that is efficient and consistent with site conditions, and compatible with surrounding development.

Architecture:

- To express an overall contemporary business environment.
- To provide opportunities for individual users to express their architectural themes, within a basic design framework.
- To promote contemporary styles, clean lines, with a distinctive image.

Landscaping:

- To provide a singular landscaping element that ties the development together.

- To establish a quality unified freeway frontage treatment.
- To provide a simple but visually interesting hierarchy of landscaping treatments throughout the development.

North Star Commerce Center

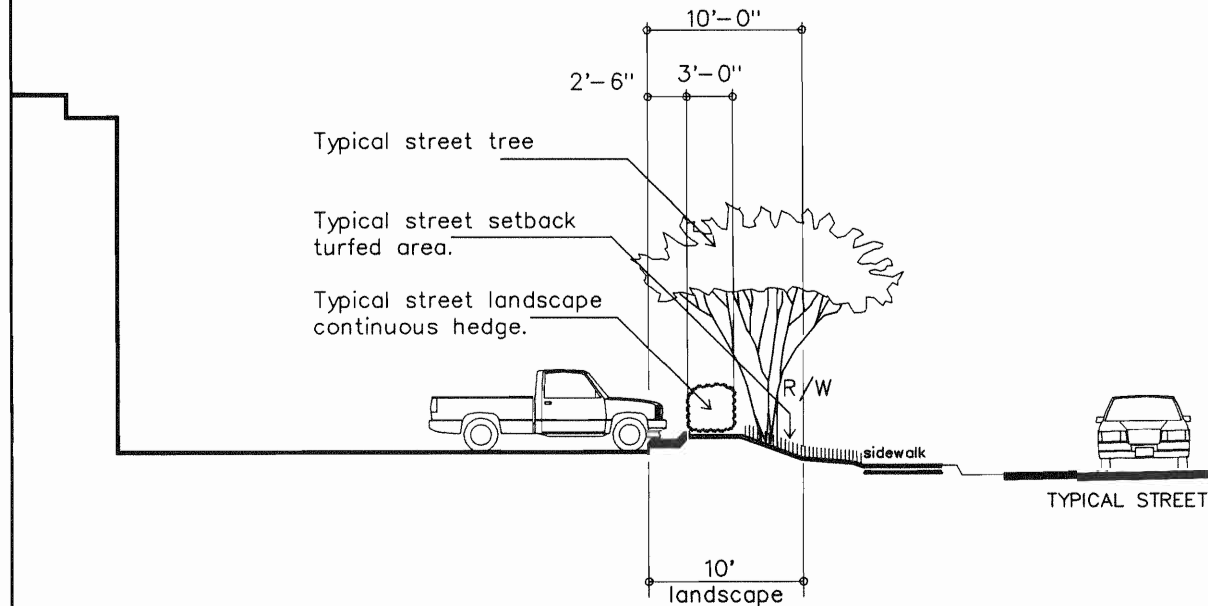
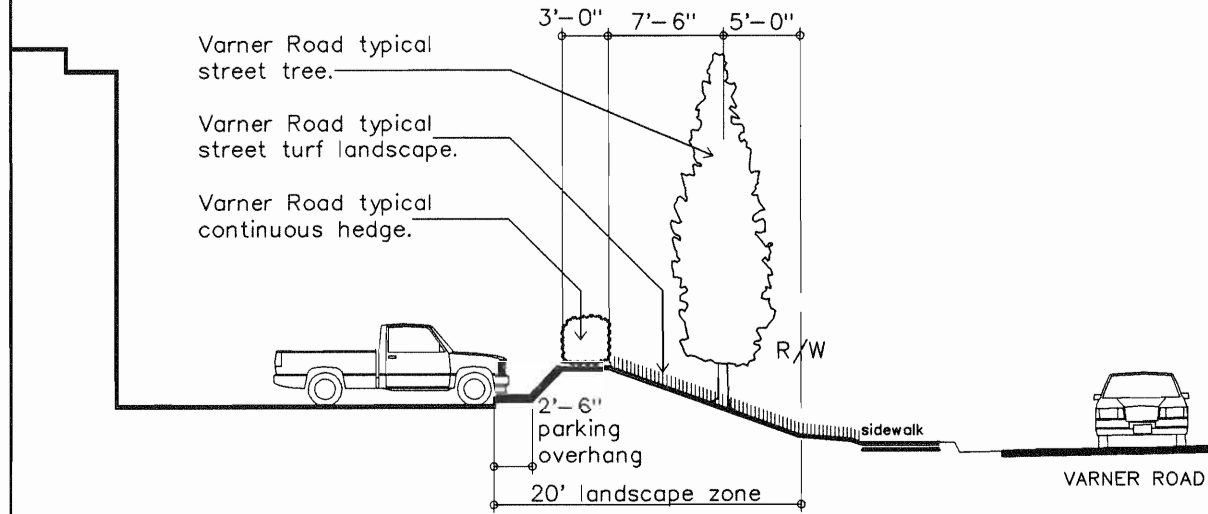

TYPICAL STREET LANDSCAPE

dc5.DWG.VVYSP2

